



Cavity Diplexers

- ◆ High Rejection
- ◆ Low Insertion Loss
- ◆ Miniaturization
- ◆ Excellent Reliability
- ◆ Customization available

The HRT-DX(GSM25)-1N is a cavity diplexer. The pass band is 1850-1915MHz and 1930-1995MHz. It has excellent isolation $\geq 70\text{dB}$ @ 1850-1915MHz and 1930-1995MHz. It has a maximum insertion loss of 0.7 dB. The diplexer has N-Female 50ohms connectors.



Electrical Specifications

Parameters	Units		ANT-RX	ANT-TX
Pass Band Frequency	MHz		1850-1915	1950-1995
Insertion Loss	dB	Max	0.7	0.7
Ripple	dB	Max	TBD	TBD
Return Loss	dB	Min	18	18
Group Delay Variation	ns	Max	TBD	TBD
Phase Matching	deg	Max	TBD	TBD
Rejection	dB	Min	TBD	TBD
Isolation	$\geq 70\text{dB}$ @1850-1915MHz,1950-1995MHz			
Power Handling	150 W(Avg)			
Port Sign	Port 1: ANT ; Port 2: RX ; Port 3:TX			

50 ohms Coaxial Cavity Diplexers

SN:0149-20220420 Version: A0

Mechanical Specifications		Environmental Specification	
Parameter	Specification	Parameter	Specification
ANT Connector	N-Female (50Ω)	Operating Temp.	-40°C to +70°C
Rx and Tx Connectors	N-Female (50Ω)	Storage Temp.	-50°C to +90°C
ROHS	Yes	Environment Class	TBD
Material	Aluminum (6061)	Altitude	30,000 ft.
Weight(Kg)	1.11		(Epoxy Sealed Controlled environment)
Surface Finish	Black Painted	Humidity	95%RH at 40°C
Shock	20G for 11msec half sine wave,3 axis both directions		
Note			

Outline Drawing:

All Dimensions in mm (inches)
Outline Tolerances $\pm 0.3(0.012)$

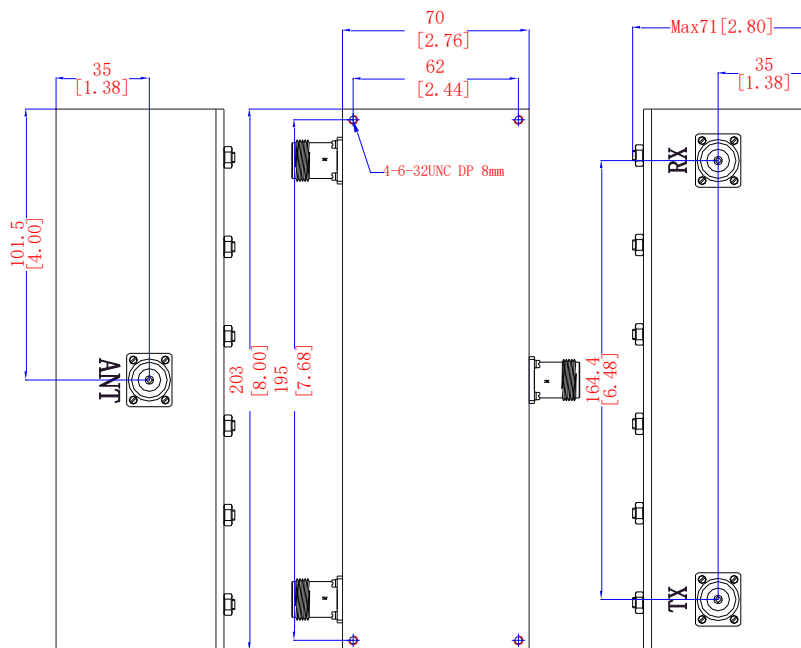

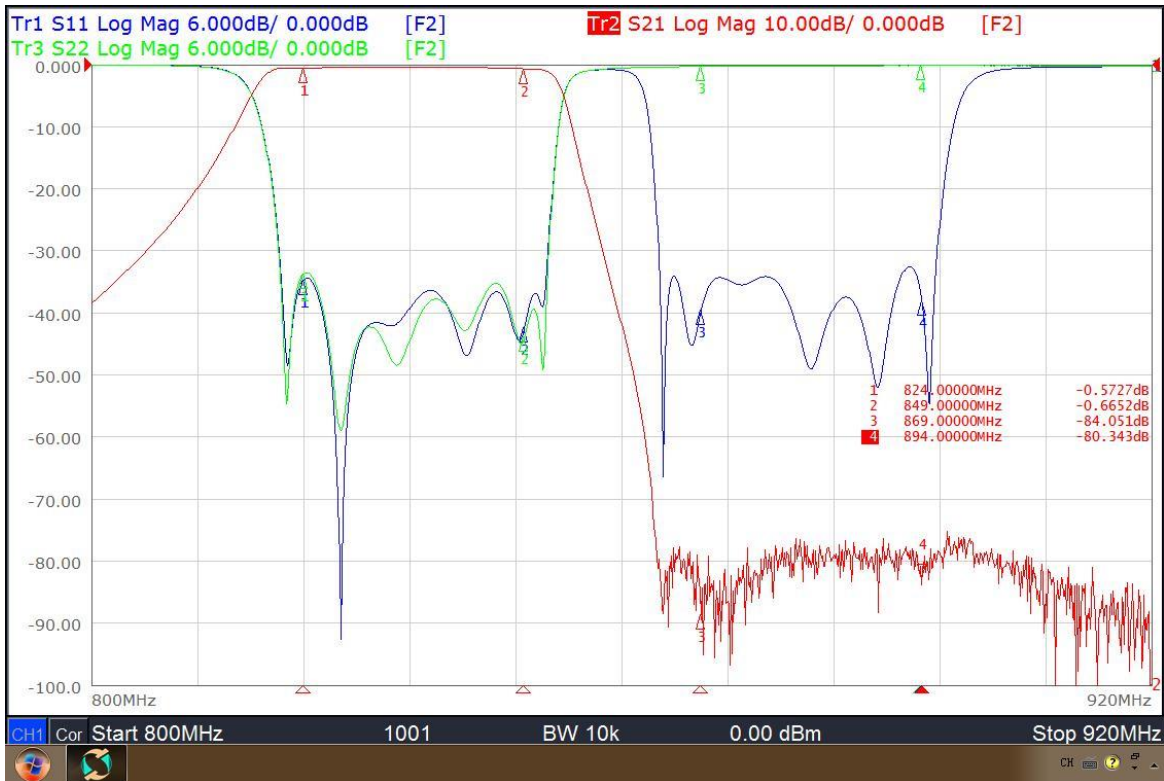
Test Plot

Test Plot
